

Oil Burner Control Box

For forced-draught burners with a capacity of over 30 kg/hour in intermittent operation, 1 or 2-stage

Flame detector:

- photo-resistor FZ 711 S
- infrared flicker detector IRD 1010

INTRODUCTION

The TMO 720-4 oil burner control box is capable of controlling and monitoring medium to high capacity forced-draught burners (tested and approved as per EN 230).

It can be employed, as preferred, for multi-stage or modulating operation, with burners of any nominal rating or with stationary warm air generators (as per DIN 4794).

The TMO 720-4 is fully interchangeable with the earlier version, the TMO 720-2.

CONSTRUCTIONAL FEATURES

The control box is enclosed in a protective, flame resistant, transparent, plug-in type plastic housing, and includes:

- Synchronous motor with reduction gearing driving cam switches
- Cam switches with informative, coloured programme indicator
- 16-way cam switch assembly controlling the programme sequence
- 2 DC relays and 1 remanence relay on a common yoke
- Plug-in printed circuit board with electronic components

On the underside of the unit are robust plug terminals where monitoring of the air damper and mode of operation ("repeat cycle" or "direct lockout") can be programmed via three wire jumpers, which may be cut as required.

The following important indicators and operating controls can be found on the front of the control box:

- Reset button incorporating a signal lamp for lockout
- Coloured programme indicator
- Central screw fastening



TECHNICAL DATA

Supply voltage	220 / 240 V (-15... +10%) 50 Hz (40 - 60 Hz)
AC frequency variations	result in proportional timing deviations
Fuse rating	max. 10 A rapid, 6 A slow
Power consumption	15 VA
Max. current per output terminal	4 A
Total	6 A
Approved for	burners of unlimited capacity as per EN 230
Pre-purge time with air damper open	30 sec.
Air damper open/close time	<60 sec.
Pre-ignition time	30 sec. or 2 sec. (terminal 10)
Safety interval (fixed)	5 sec.
Post-ignition time (fixed)	7,5 sec.
2nd stage delay	11,5 sec.
Reset delay	none
Permissible ambient temp.	-20° C... +60° C for control box and photo-resistor
FZ 711 S light sensitivity	
Red lettering	better than 10 lux, radial
White lettering	better than 10 lux, axial and radial
Photo-resistor cable length	Standard 0.6 m, max. 10 m, max. 200 m laid separately
Insulation standard	IP 44
Weight	approx. 950 g with baseplate and photo-resistor

TECHNICAL FEATURES

1. The control box and photo-resistor can be operated at an ambient temperature of up to 60° C.
2. The timing sequence is controlled by a synchronous motor driving a cam switch assembly. Timing is therefore practically unaffected by variations in the mains voltage.
3. A coloured programme indicator allows visual monitoring of the programme sequence.
4. A remote reset switch can be connected in addition to the built-in reset switch on the control box. Provision has also been made for a remote lockout indicator.
5. A keyed fit ensures that the wrong type of control box cannot be fitted to the baseplate.
6. DC operation of both relays is reliable and clear-cut, at the same time providing a check of the mains voltage.
7. Wiring of the baseplate is eased by the provision of 4 neutral and 3 earth terminals.
8. By cutting the appropriate wire jumper on the underside of the unit, "direct lockout" or "repeat cycle" operating modes can be programmed. The air damper monitoring mode is selected in the same way.
9. If no return signal is received indicating that the air damper has reached the end of its travel, the control box switches to lockout, causing the burner system to shut down.
10. No separate air damper contact is required for release of the high-flame valve.
11. Short or long pre-ignition time can be selected.
12. All electrical and electronic components are incorporated on two plug-in type printed circuit boards.

INSTALLATION INSTRUCTIONS

1. The control box can be mounted on the burner, or installed as part of a separate switching system. It is suitable for mounting in any attitude.
2. The wiring must be checked exactly, ensuring that the control box has been correctly installed. Incorrect wiring puts the safety of the burner system at risk, and could cause damage to the control box or system.
3. It is important that no stray light is allowed to reach the photo-resistor. Stray light can enter the burner through the inspection window or through cracks, or be caused by the glowing refractory layer on the inside of the combustion chamber.
Stray light can cause the control box to switch to lockout.
4. The control box and photo-resistor should be mounted in a position where the ambient temperature cannot, on any account, rise above 60° C. At higher temperatures there is a risk of unreliable operation, and the life of the control box will be reduced.
5. The unit is designed to withstand moderate vibration, as experienced in burner systems. It should, however, be mounted in a position where it is not exposed to harsh vibration and is protected from bumps.
6. If during the test of the burner the click-rate (according to EN 55014) is higher than the max. allowed valve, a X2-capacitor of 0.1 µF can be connected between terminal 8 and 9.

PROGRAMME SEQUENCE

Normal start procedure

When the controlling thermostat calls for heat, the burner motor and ignition circuits are switched on. If no air damper lock is fitted, the sequence switches immediately to pre-purge. Otherwise, the sequence only continues when the signal indicating opening of the air damper has been received.

After 30 sec. pre-purge time, the signal commanding the air damper to remain open is interrupted and the switching sequence stops until the "air damper min." signal is received.

The programme sequence is not interrupted if no air damper monitoring is employed. The switching sequence continues and the low-flame valve is opened.

When the flame has been established, and is "seen" by the photo-resistor, the built-in flame-monitoring relay allows the programme sequence to continue to post-ignition and high flame.

The release for high-flame operation causes a voltage to be applied to the high-flame thermostat via terminal 6. If the thermostat demands high flame, the air damper is first opened via terminal 12. On receipt of the signal for "air damper max.", high-flame valve V2 is also opened.

Programme sequence switching finally stops and the control box is in its normal operating mode.

Start sequence without establishment of flame

Less than 5 sec. after release of fuel, the control box switches to lockout.

The indicator on the reset button lights up. The burner system only goes back into operation after the built-in reset button has been pressed or the remote reset has been activated. The normal start sequence begins again after reset, at the end of the safety interval.

Loss of flame during operation

Loss of flame during operation is instantly detected by the photo-resistor due to the absence of radiated light. Depending on how the control box has been "programmed", this is followed by:

- a) If jumper II has been cut for "repeat cycle" operation:
Immediate interruption of the supply of fuel and repeat of normal start sequence.
- b) If jumper II is intact, for "direct lockout" operation:
The control box immediately switches to lockout. A new start sequence can only begin after the reset button has been pressed.

When the ignition transformer is connected to terminal 10, the control box employs a short pre-ignition period. In this way, the ignition procedure is only initiated at the end of pre-purge.

PROGRAMME SELECTION

"Repeat cycle" or "direct lockout"

Jumper II on the underside of the unit should be cut if the control box is required to repeat the start sequence after loss of flame during operation.

By connecting terminals 17 and 18 on the baseplate, the control box can again be programmed for "direct lockout" operation.

Monitoring of the air damper

No monitoring:

Jumper I on the underside of the unit should be left intact. Terminals 14 and 15 on the baseplate should be connected together.

Monitoring of "air damper max.":

Jumper I on the underside of the unit should be left intact. Switch indicating end of air damper travel should be connected between terminals 14 and 15.

Monitoring of "air damper min.":

Cut jumper I on the underside of the unit. Connect terminals 14 and 16 together and the air damper end switch between terminals 14 and 15.

Monitoring of air damper "max." and "min.":

The circuit should be as shown in fig. 1, with wire jumper I on the baseplate cut.

No lockout caused by absence of signal indicating air damper at end of travel:

Jumper III should be cut

- e.g.:
- If air damper open/close time is greater than 60 sec.
 - In conjunction with pre-heating for heavy oil

CIRCUIT DIAGRAM - WITH AIR DAMPER CONTROL

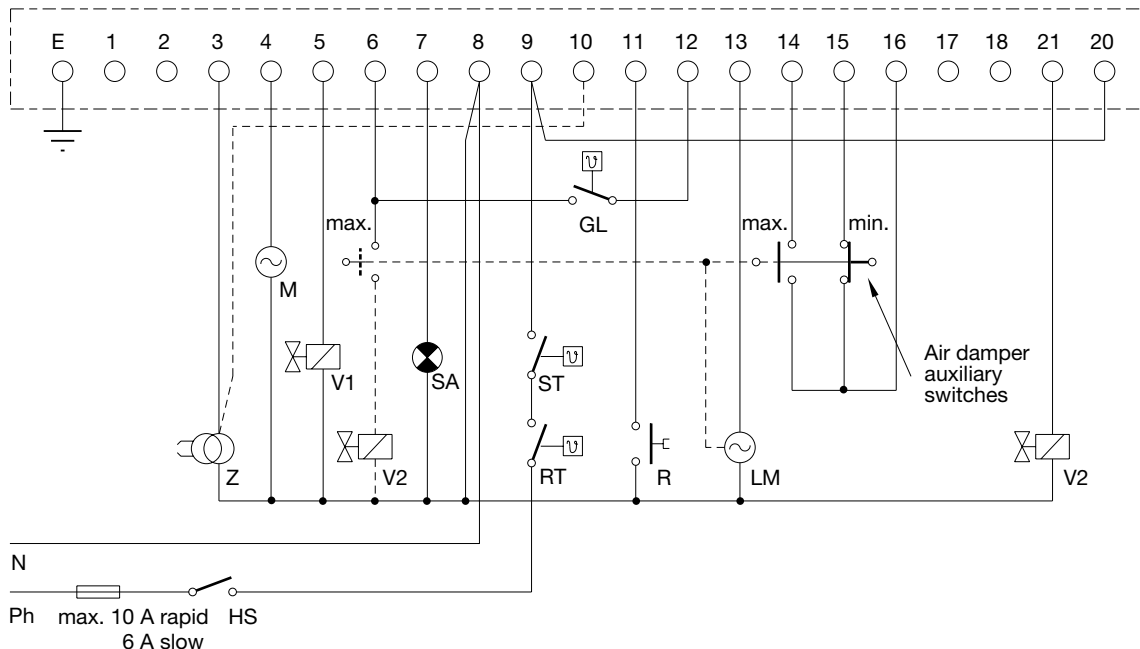

FZ WIRING DIAGRAM

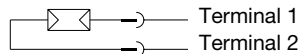

IRD CONNECTION

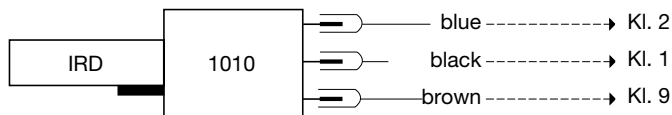

- HS Main switch
- ST Safety thermostat
- RT Controlling thermostat
- GL High-flame thermostat
- SA Remote lockout indicator
- LM Air damper motor
- M Burner Motor
- Z Ignition
- R Remote reset
- V1 Solenoid valve, low flame
- V2 Solenoid valve, high flame
- FZ Photo-resistor

REFERENCE WIRING V2

- On actuating-drives with 1 "max."-contact:
V2 on terminal 21.
- On actuating-drives with 2 "max."-contacts:
V2 by 2nd "max."-contact on terminal 6.

CIRCUIT DIAGRAM - WITHOUT AIR DAMPER CONTROL

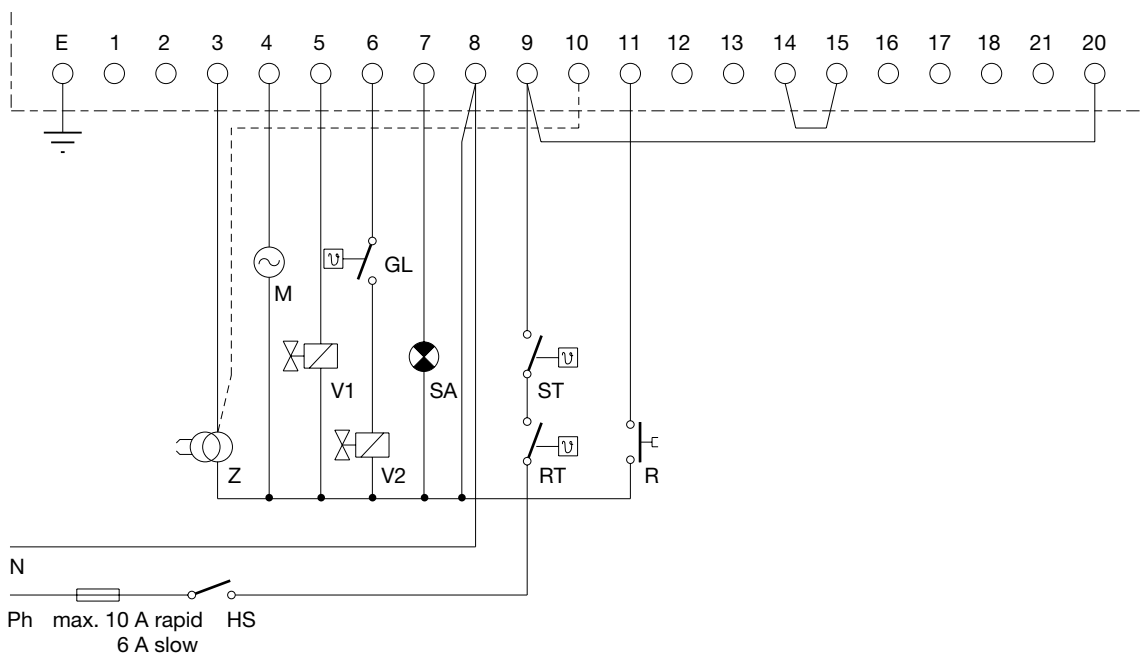

GENERAL CIRCUIT DIAGRAM

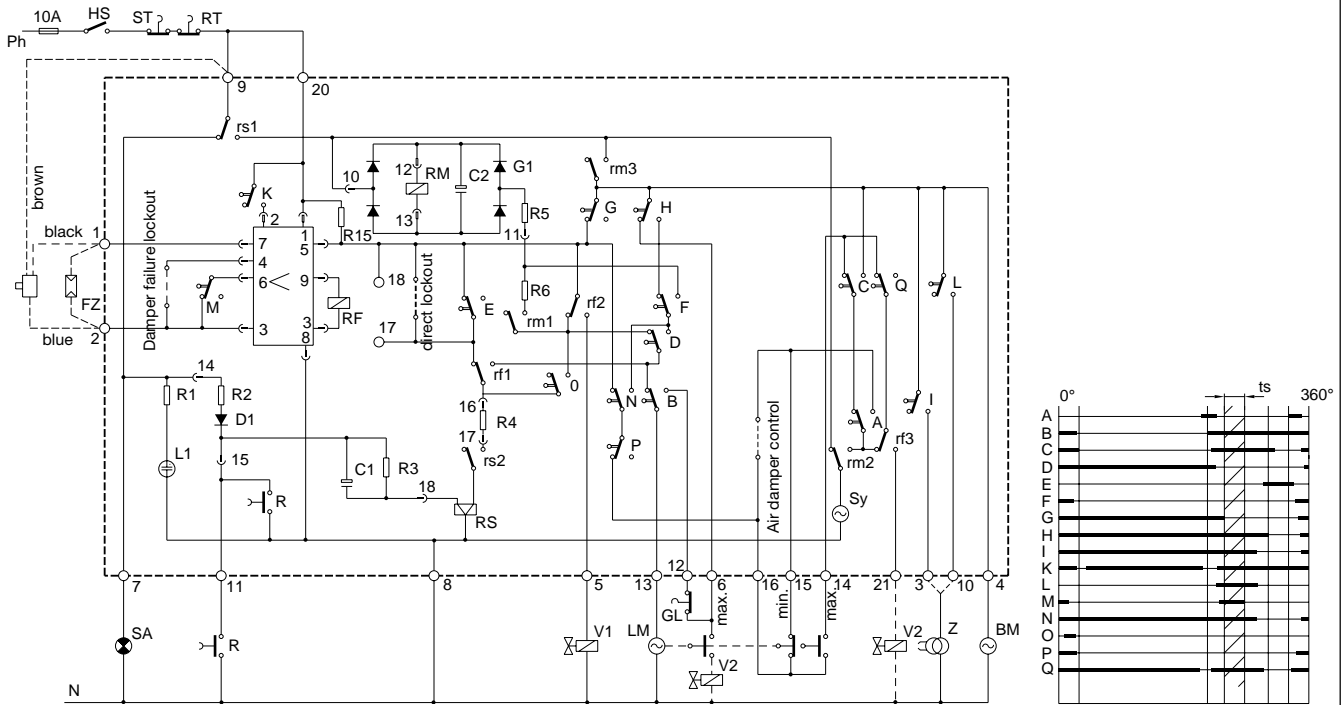

- | | | | | | |
|----|---------------------------|---|---------------------------|-----|---------------------------------|
| RM | Motor relay | E | Repeat cycle | | Relay contacts |
| RF | Flame relay | F | RM on and hold | rs1 | Lockout shutdown |
| RS | Lockout relay | G | V1 open, beginning of ts | rs2 | Lockout relay self interrupt |
| R | Reset | H | Release for high flame | rm1 | RM hold |
| | Cam switches | I | Long pre-ignition | rm2 | Synchronous motor control |
| A | Synchronous motor control | K | LM operation supervision | rm3 | Main contact |
| | Air damper monitoring | L | Short pre-ignition | rf1 | Lockout initiation |
| B | Air damper control | M | Programme start | rf2 | Hold V1 |
| C | Synchronous motor control | P | Check rf1 | rf3 | Hold V2 |
| | Air damper monitoring | Q | Synchronous motor control | tv | Pre-purge time with damper open |
| D | Switchover to RM hold | | Air damper monitoring | ts | Safety time |

PROGRAMME SEQUENCE

a) Start sequence, flame established

b) Start sequence, flame not established

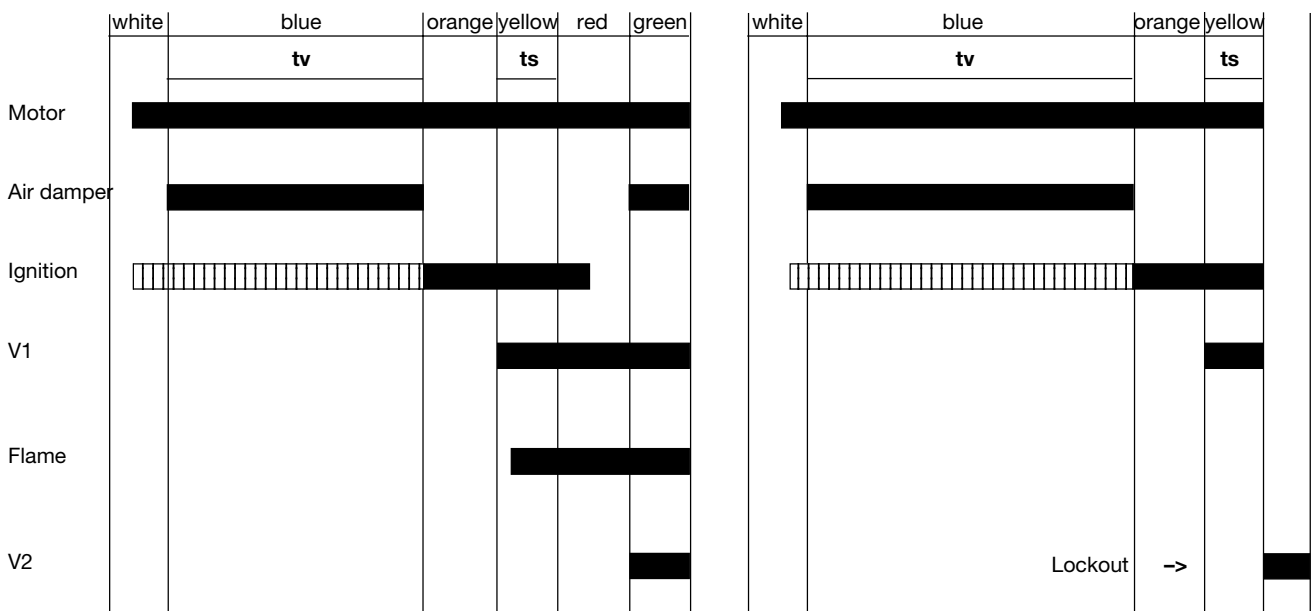

SUMMARY OF ALL SAFETY FEATURES

1. Loss of flame during operation results in immediate cancellation of fuel release, followed by direct lockout or repeat of start sequence, as desired.
2. Start without flame establishment causes cancellation of fuel release within 5 sec. of its initial release.
3. Fuel is supplied only when all parts of the unit are functioning correctly. All safety circuits are automatically checked before fuel is released.
4. Continuous air damper monitoring is possible, with air damper failure resulting in lockout. This precaution also protects the ignition transformer from overload.
5. Failure of the mains supply always results in a normal start sequence on restoration of power. If the control box is at lockout, failure of the mains supply does not cause it to reset.
6. Stray light during the pre-purge phase leads to shutdown and lockout.
7. Increased sensitivity of the flame detector during the pre-purge phase ensures that stray light is detected, or deterioration of the photo-resistor's capabilities is noticed before it becomes a risk to the safety of the system. The circuit responsible for stray light security is of a fail-safe design.

COMMISSIONING AND MAINTENANCE

The control box requires no maintenance. It should therefore not be opened.

The photo-resistor should be checked periodically at the light-sensitive side for cleanliness. Dirt and dust reduce the amount of light it receives, which could lead to a shutdown. Due to the very low variations in the voltage produced by the photo-resistor, measurement of this voltage does not provide reliable results. As a test, a resistor (R=4 k 7) should be connected in series with the FZ 711 S. If the control box does not go to lockout when the next start sequence begins, the amount of light being "seen" by the photo-resistor is satisfactory.

The resistor must be removed when the test has been completed.

On commissioning the system, and when carrying out servicing work, correct operation of the monitoring systems should be checked as follows:

1. Attempt to start the burner with the photo-resistor pulled out and covered up. Lockout should take place at the end of the safety interval (yellow sector). The photo-resistor must be well covered up, otherwise lockout will occur due to stray light.
2. Attempt to start with the photo-resistor exposed to stray light (the lighting in a reasonably bright room is sufficient). A stray-light shutdown should result.
3. Start the system, with the photo-resistor in position, allowing the flame to become established and the programme sequence to complete (end of green sector). Pull out the photo-resistor and cover it up. The result should be as follows:
 - a) Lockout, if the control box is programmed for "direct lockout" operation
 - b) If programmed for "repeat cycle" operation, fuel should be cut off immediately, and the sequence restarted.

ADDITIONAL SAFEGUARD AGAINST STRAY LIGHT AND PHOTO-RESISTOR FAILURE

During the pre-purge phase, the control box increases the sensitivity of the flame signal amplifier to a level considerably higher than that for normal burner operation.

The slightest stray light, or even a minor deterioration of the photo-resistor's operating characteristics, cause a stray-light shutdown before fuel is released.

FAULT FINDING

1. Burner does not start, programme indicator stops at end of green section, no lockout indicated:
 - a) Incorrect wiring
 - b) No voltage at terminal 9
 - c) No neutral connection
2. Lockout, with programme indicator at beginning or end of blue section:
 - a) No signal indicating "damper max."
 - b) No signal indicating "damper min."
 - c) In systems which do not provide monitoring of the air damper position, jumper I on the underside of the unit has been cut, or the connection in the baseplate between terminals 14 and 15 is missing.

Caution: The signals indicating the air damper positions "max." or "min." for pre-purge or end of ignition, must be received within 60 sec. At the end of this delay, lockout will occur, preventing the burner from remaining permanently on pre-purge.

3. Lockout in blue section:
 - a) Stray light detected by photo-resistor
 - b) Photo-resistor defective
 - c) Solenoid valve leaking or open
 - d) Defect in control box flame-monitoring circuit
4. Burner starts and fuel release signal is given, but no flame is established. Lockout at the end of the yellow section:
 - a) No ignition
 - b) Fuel supply fault
 - c) Solenoid valve defective or not connected
5. Burner starts and flame is established, lockout occurs at the end of the yellow section:
 - a) Photo-resistor is dirty
 - b) Photo resistor installed incorrectly-"sees" no light
 - c) Photo-resistor defective or connected incorrectly
 - d) Control box flame-monitoring circuit defective
 - e) No voltage at terminal 20

Caution: When a control box switches to lockout, it is, in most cases, performing the function for which it was designed. Apart from the possibilities already mentioned, lockout can be caused by one or more of the following:

- 1) Ignition spark in wrong position
- 2) Fuel tank empty
- 3) Fuel valve closed
- 4) Oil filter blocked
- 5) Defective oil pump
- 6) Poor combustion
- 7) Unreliable burner start

TMO 720-4 WITH BASEPLATE

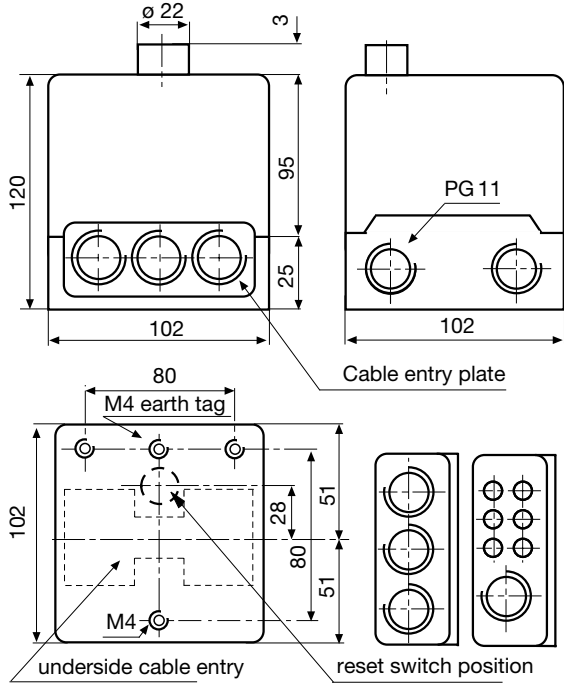

FZ 711 S PHOTO-RESISTOR

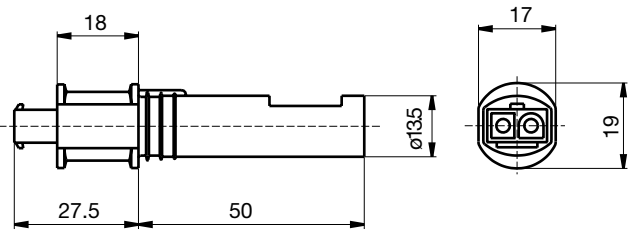

HOLDER ZU FZ 711 AND IRD 1010

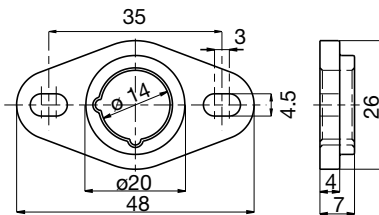

IRD 1010

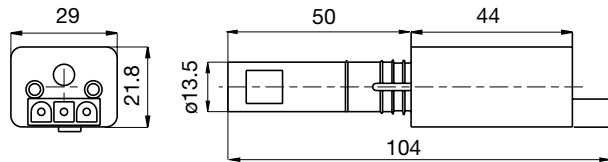

IRD VARIATIONS

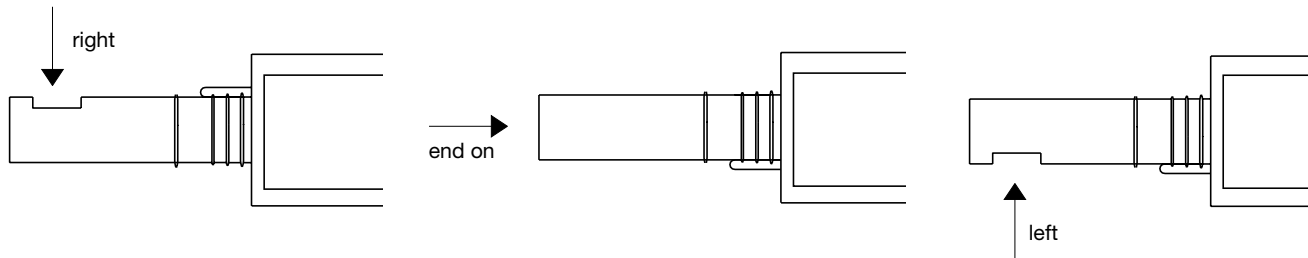

ORDERING INFORMATION

ITEM	DESIGNATION	ITEM NO.
Control box	TMO 720-4	08001
Baseplate	TMO base	70201
Insert plate (2x)	PG plate	70502
optionally	Cable entry plate	70501
Flame detector	FZ 711 S red	40001
optionally	FZ 711 S white	41001
Infrared flicker detector	IRD 1010 right	16501
optionally	IRD 1010 end on	16502
optionally	IRD 1010 left	16503
Flame detector mount	FZ Holder M74	59074
FZ 711 S cable	Sensorcable, 2-wire, 0.5 m with tag wire ends	7225001
IRD / FZ cable	Sensorcable, 3-wire, 0.6 m, with tag wire ends	7236001

The above ordering information refers to the standard version.
Special versions are also included in our product range.

Specifications subject to change without notice.

TMO 720-4



Satronic AG
Brüelstrasse 7
Postfach 324
CH-8157 Dielsdorf