

# Oil Flow Meter and Hours of Operation Counter

For single or two-stage oil burners with throughputs from 1 to 40 l/h

- multifunctional
- mains or battery powered

## INTRODUCTION

The oil flow meter and hours of operation counter is used on single or two-stage burners with throughput rates from 1 to 40 l/h of heating oil EL. It provides the user with various information, such as oil consumption, number of starts, hours of operation, etc. plus a warning indication if the flow rate falls below a preset nominal level, due to either an obstructed nozzle or filter. By identifying problems with the oil flow, inefficient combustion and air pollution may be corrected.

The sensor is mounted between the oil pump and the nozzle.

The display can be mounted anywhere on the burner. It is available in either a mains or battery powered version.

## CONSTRUCTIONAL FEATURES

The sensor is an oval tooth-wheeled counter with very small dimensions (30 x 30 x 34 mm). The enclosed oil volume is only 2 ccm. The material used guarantees high accuracy and long life. A filter, which is easy to change, protects the sensor from any floating particles.

The display is enclosed in a plastic housing, which fits into a standard 22.2 x 45 mm cutout. Located on the front are a LCD display (6 digits, with leading-zero suppression, metered units, warning and operating mode symbols) and a push button switch for selecting the operating mode and resetting.

Connectors for the sensor and power cable, plus a code switch to select the operating mode, are located on the back. The connector for the power supply is only mounted on the mains powered version. The battery is located in a battery box.

The sensor is connected to the display by a 2 wire plug and cable.

## TYPES AVAILABLE

SOG 960	sensor for heating oil EL
SOZ 960 B	display with battery
SOZ 960 N	display for mains supply



## TECHNICAL DATA

### Sensor SOG 960 for heating oil EL

Throughput	1 to 40 l/h
Max. pressure	< 25 bar
Ambient temp. range	0 to 60° C
Accuracy	±2,5% (at a volumetric weight of 830 g/dm <sup>3</sup> )
Oil volume	2 ccm
Loss of pressure	≤ 0.1 bar
Electrical connection	2-wire AMP connector Modu 2 system
Oil connection	R 1/8"
Mounting attitude	Any
Weight	110 g

### Display general

Front dimensions	48 x 24 mm
Cutout	45 x 22,2 mm (DIN 43700)
LCD display	6-digits, w. leading zero suppres.
Digit size	8 mm
Ambient temperature	0 to 60° C
Insulation standards (IEC 144)	Front IP 65 Connectors IP 20
Mounting attitude	Any

### Display SOZ 960 N mains

Supply voltage	220 / 240 V (-15... +10%) 50 Hz (40-60 Hz)
Current	10 mA
Power connector	2 wire Satronic connector
Sensor connector	2 wire AMP connector Modu 2 system
Display visible after loss of power	ca. 24 h (0-Serie: ca. 3 h)

### Display SOZ 960 B battery

Lifetime of battery	ca. 5 years (0-Serie: ca. 3 years)
End-of-life warning	> 1 year before end-of-life
Data held during battery change	2 minutes
Battery	CR 14250, 3 V, 850 mAh
Sensor connector	2 wire AMP connector Modu 2 System

## TECHNICAL FEATURES

### 1. Combination of display and sensor

Display and sensor can be mixed, if the digits of the type are matching, e.g.:

SOZ 960 B + SOG 960 or  
SOZ 960 N + SOG 960

### 2. Operation of battery-powered type

Displays with batteries need no mains and are, therefore, especially suitable for adding to burners in the field. The lifetime of the battery is approximately 5 years. One year before the end-of-life, the crossed battery symbol  appears on the display.

### 3. Operation of mains powered type

The display is connected to the mains (220 / 240 V AC) by means of a 2 wire plug and cable. The display disappears 2 days after loss of power. All data is retained and can be displayed when power is restored.

Set- and reset functions are not possible at mains interruption.

### 4. Mounting and installation

The sensor is connected by R 1/8" screw fittings into the oil tube between the oil pump and nozzle in the flow direction as stated on the sensor (any mounting attitude). The display can also be mounted in a panel with a 45 x 22.2 mm cut-out. The connection between the sensor and the display is made by a 2 wire cable and plug. For the power connector (mains version only), the appropriate standards must be complied with.



Inside view

## COMMISSIONING AND MAINTENANCE

### 1. Function of the push button mode

By pressing the push button, the various modes can be selected in succession. Each mode is displayed by its function symbol as well as the appropriate unit. The selected mode remains present until the push button is pressed again. The new function is first displayed when the push button is released. With the same push button, the reset signals for the sum-counter, total reset and threshold levels (for the service function) are generated.

Mode	Function	7-digit display	unit
	actual consumption	6-digits 2 decimal places (0000.00)	Oilflow in liter per hour (l/h)
2.	actual consumption 2nd stage	6-digits 2 decimal places (0000.00)	Oilflow in liter per hour (l/h)
◇	sum counter (resetable)	6-digits 0 decimal places (000000)	Oilflow in liter (l)
*	totalizer	6-digits 0 decimal places (000000)	Oilflow in liter (l)
⌚	total hours of operation	6-digits 0 decimal places (000000)	hours of operation (h)
∩	number of starts	6-digits 0 decimal places (000000)	number of starts
2.⌚	hours of operation, 2nd stage	6-digits 0 decimal places (000000)	hours of operation 2nd stage (h)
∩ 2.	number of starts, 2nd stage	6-digits 0 decimal places (000000)	number of starts 2nd stage

#### Function



reduced flow rate



battery life cycle < 1 year

## 2. Selection of the operating mode

2 operating modes can be selected by setting the code switches on the back.

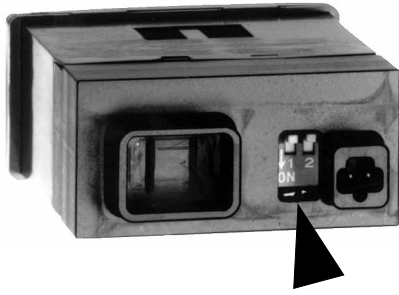

### Code switch 1 to "off" (default, factory setting)

Single stage burner (also with soft start function)  
The following functions will be displayed:

- actual consumption
- ◇ sum counter
- \* totalizer
- 🕒 total hours of operation
- ⌋ number of starts
- ⚠️ Service reduced flow rate
- 🔋 battery life cycle < 1 year

### Code switch 1 set to "ON"

Two-stage burner, for genuine 2 stage operation.  
All possible functions will be displayed.

### Code switch 2 has no function

## 3. Sum counter reset

In the mode ◇, function sum counter, resetting the sum counter can be done by this procedure:

-> *press the button for at least 10 secs.*

press the button, after 5 secs. the displayed value flashes for 5 secs. After this, the original value is displayed continuously, now release the button  $\begin{matrix} \text{I} \\ \text{I} \end{matrix}$ , is now displayed.

## 4. Total reset

A total reset is possible, but should only be done with the agreement of the manufacturer

## 5. Service function

Besides displaying various data such as actual consumption, number of starts and hours of operation, it will also detect whether the oil throughput has fallen by more than 10% of the nominal value, due to either an obstruct in the nozzle or preheater failure; on condition the value of the throughput has been presetted previously at a correct operating burner (see item 6). If after the reset routine the throughput has fallen by more than 10%, the service symbol  $\begin{matrix} \text{I} \\ \text{I} \end{matrix}$  will appear.

By recognising and solving this problem, long term inefficiency and air pollution can be avoided.

## 6. Determining the momentary throughput

Determining the momentary throughput is done in the normal mode, function actual consumption:

-> *press the button for at least 30 secs., but not longer than 32 secs.*

press the button, after 25 secs. the displayed actual consumption flashes for 5 secs. After the display stopps flashing, release the button. As a confirmation, the service symbol  $\begin{matrix} \text{I} \\ \text{I} \end{matrix}$  and the actual consumption as the new defined preset value flash for 5 secs.

On 2-stage burners, preset levels for both stages can be stored. After a change of the heat rating (replaced nozzle, different pump pressure etc.), the preset value has to be newly determined as described above. The original value will be overwritten by the new value.

## 7. Deactivation of the service function

Same procedure as under item 6 but the button has to be pressed for more than 32 secs. By doing this, the preset value and the service symbol will be resetted:

-> *press the button for more than 32 secs.*

After releasing the button, as a confirmation the service symbol  $\begin{matrix} \text{I} \\ \text{I} \end{matrix}$  and the zero-value flash for 5 secs.

## 8. Maintenance, Filter

To avoid obstruction of the sensor, as a precaution a microfilter has to be installed upstream of the burner. Filter size: less than or equal to 150 µm.

To trap single floating particles, a rough filter is built into the sensor.

**OVERALL DIMENSIONS SOZ**

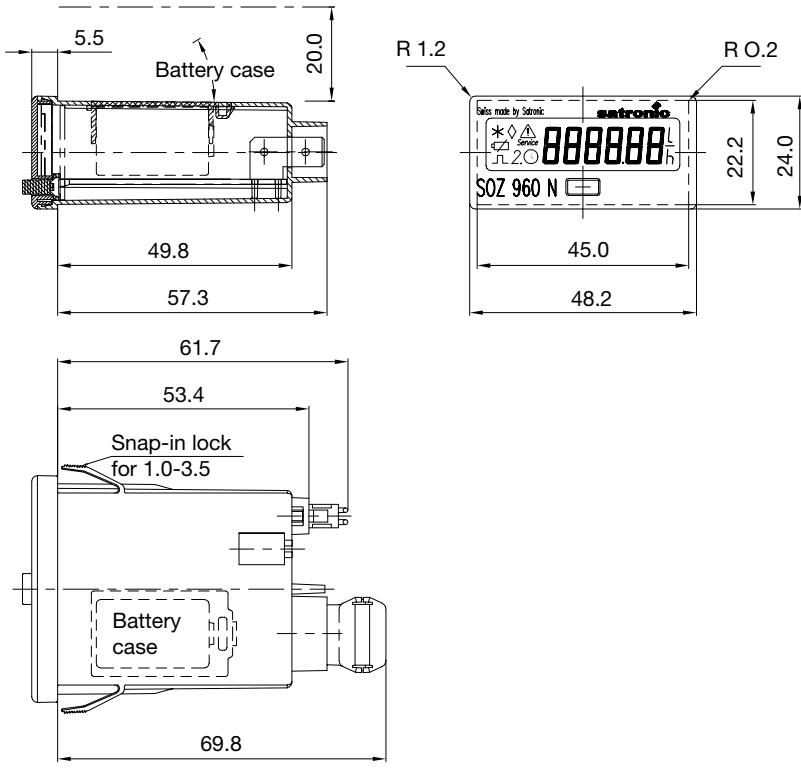

**OVERALL DIMENSIONS SOG**

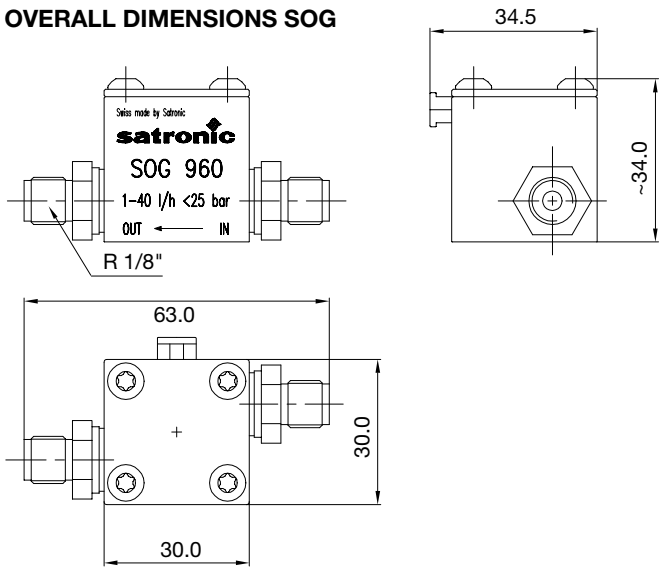

**ORDERING INFORMATION**

ITEM	DESIGNATION	ITEM NO.
sensor for heating oil EL	SOG 960	21010
display with battery	SOZ 960 B	21110
display for mains supply	SOZ 960 N	21120
power cable for display L 500 mm	power cable 2-wire 0.5 m	7295001
connection cable sensor/display L 900 mm	connection cable SOG/SOZ 0.9 m	72090

The above ordering information refers to the standard version. Special versions are also included in our product range.

Specifications subject to change without notice.

**SOG 960**  
**SOZ 960**



Satronic AG  
Brüelstrasse 7  
Postfach 324  
CH-8157 Dielsdorf